

Robot Parts

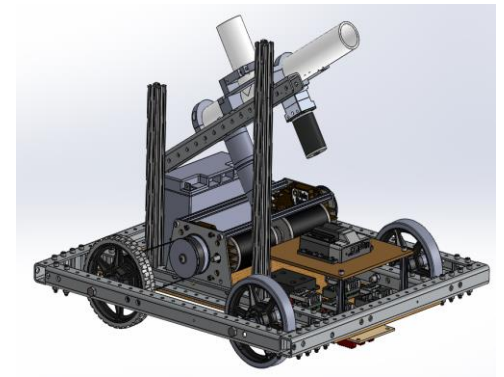

Robot Binder

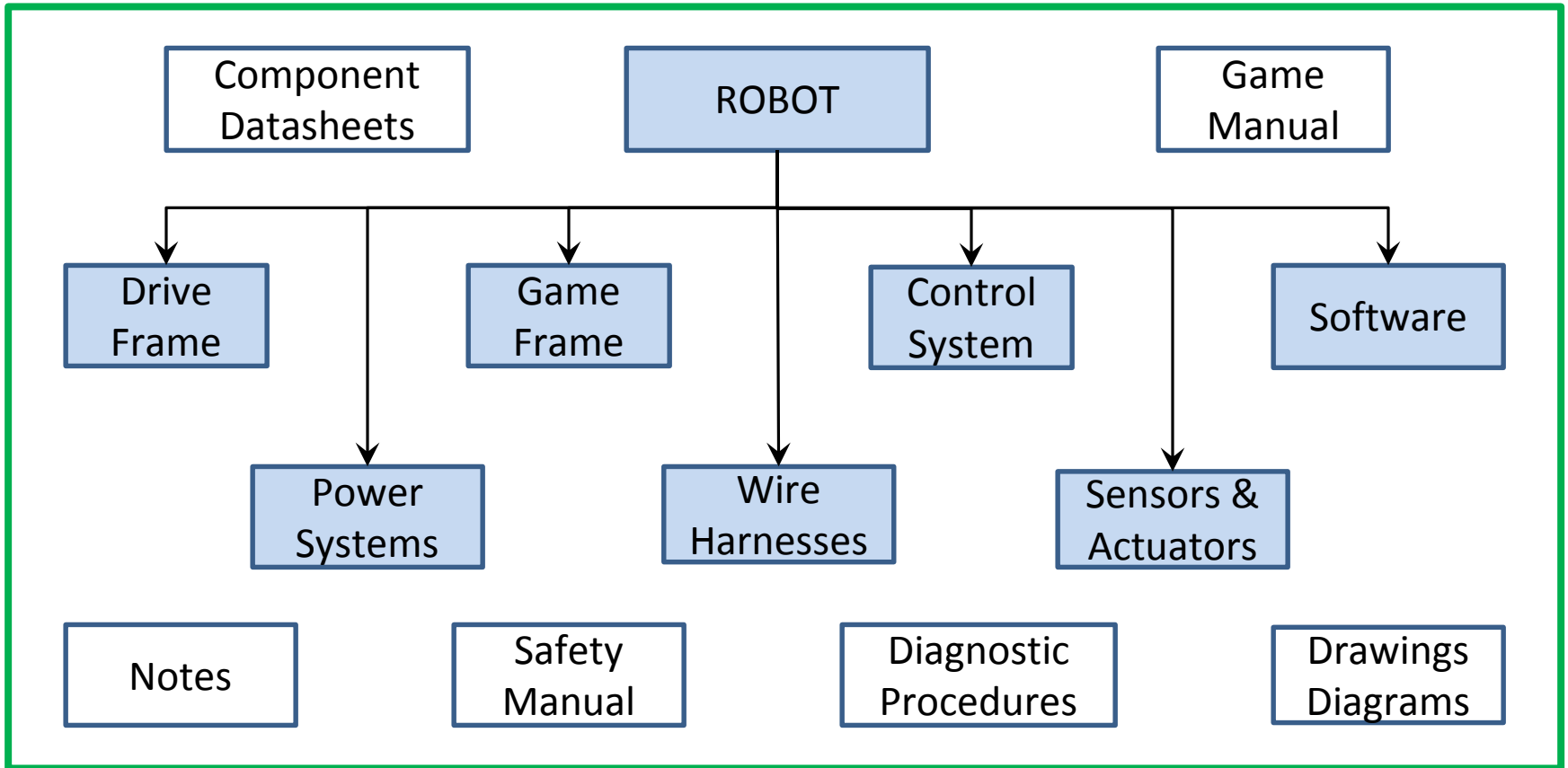

Drive Frame & Power System Assembly

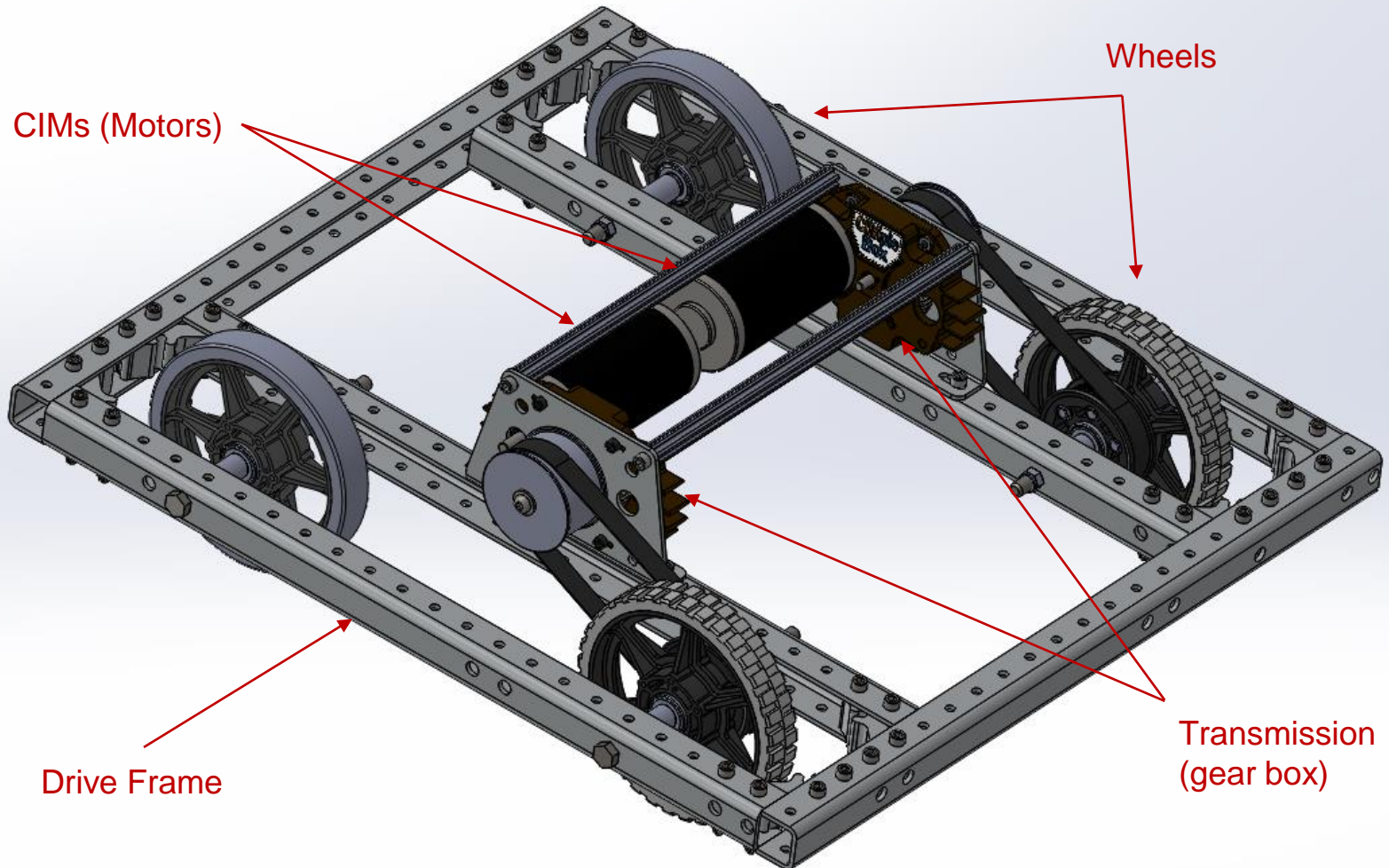

Electrical Platter (Controller, Battery & Power Distribution)

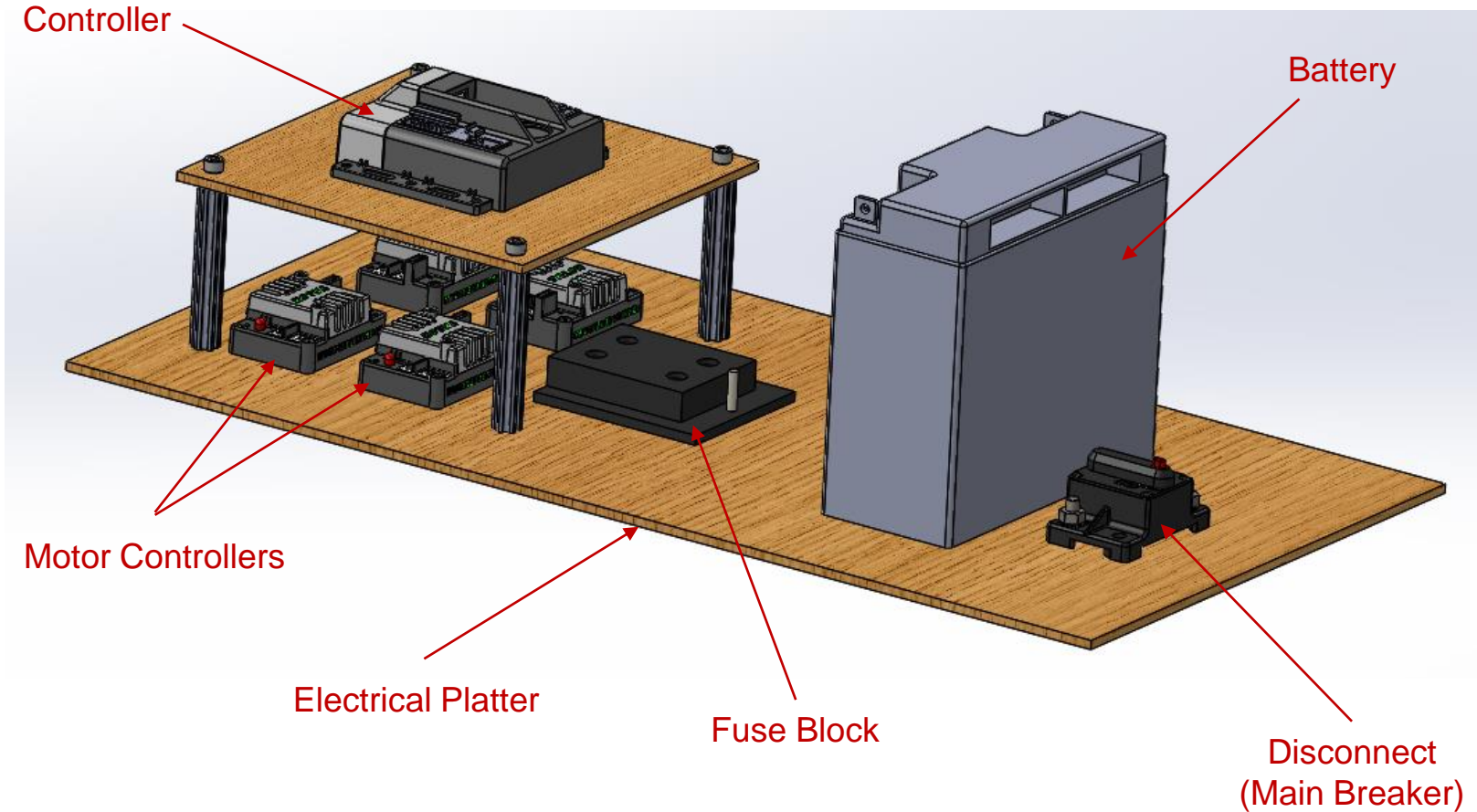

VEX Control System

Controller



Joystick

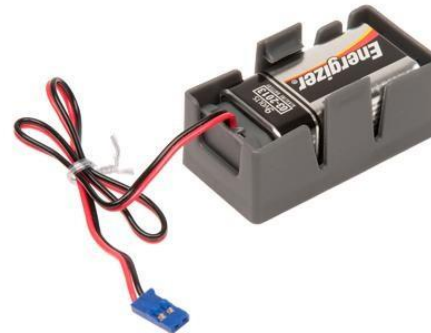

Controller
Backup
Battery

New FRC Control System

2015 FRC® Control System Layout

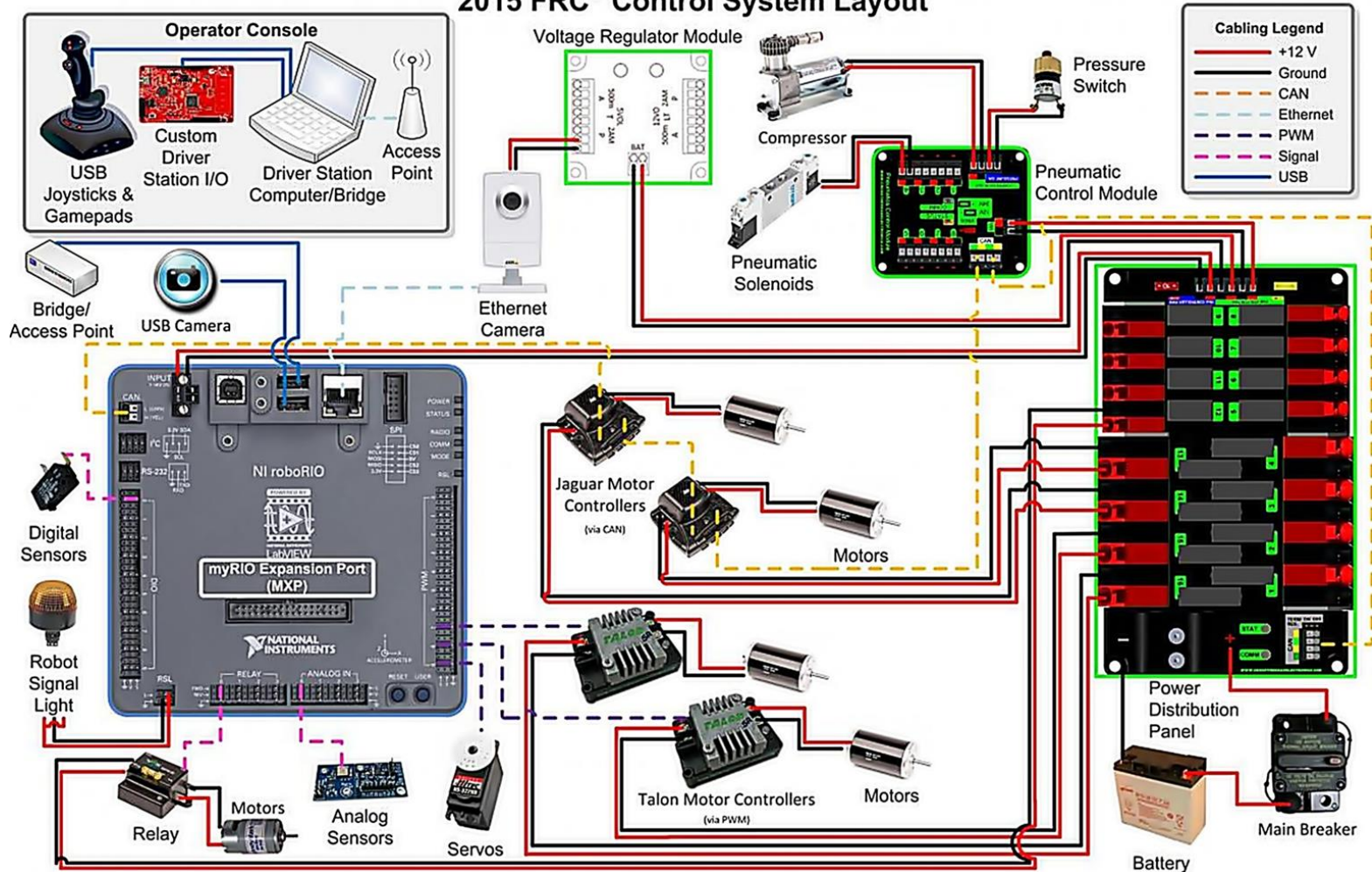

Motor Drivers

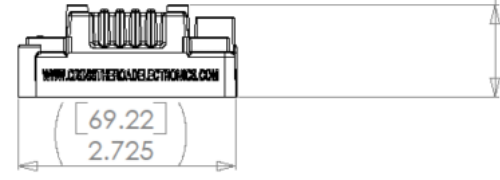
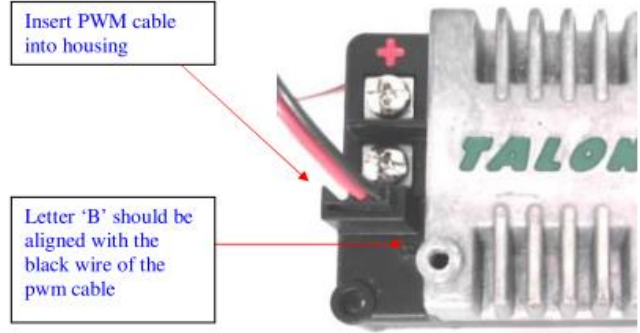
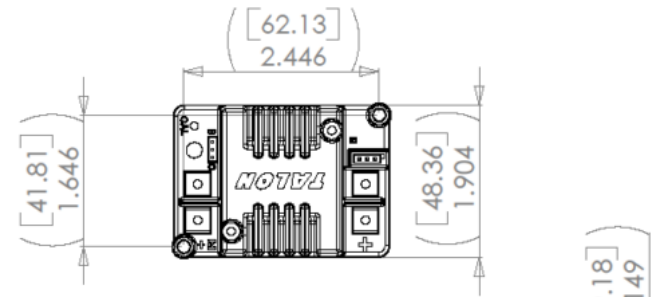

Input voltage	6-28 VDC
Continuous current	60 A
Peak current	100 A
Input PWM signal	1-2 ms @ 333 Hz
Input resolution	10-bit (1024 steps)
Output resolution	10-bit (1024 steps)
Output switching frequency	15 kHz

Sensors



Line Trackers
Must be 1/8" from Target



Push Buttons

Ping-Pong Shooter Assembly

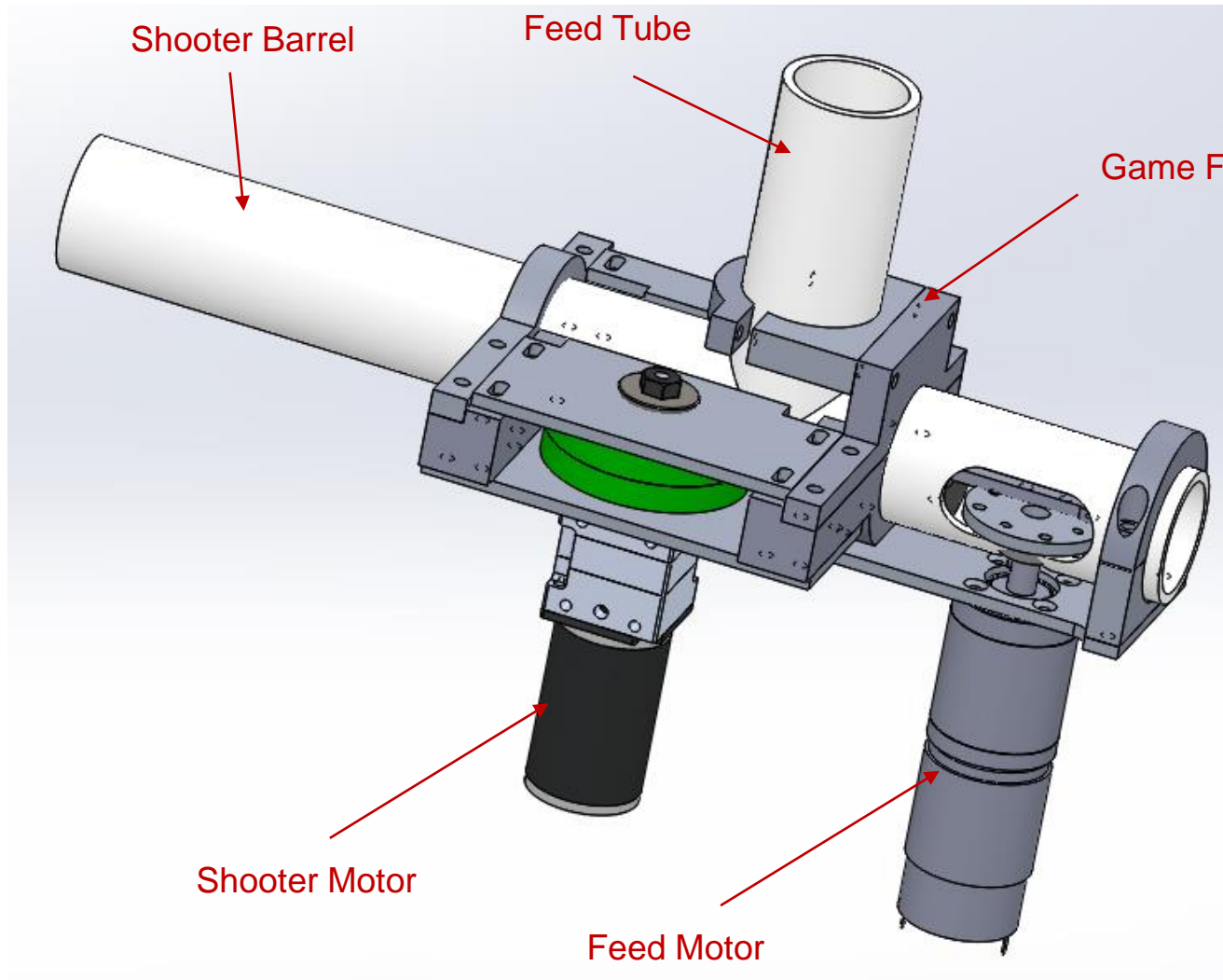

Y1 Robot Full Assembly

